

**Together,  
We Are Stronger**

KATUN GPI



GPI CO., LTD.

KATUN & Cartridge Web™  
alternative solution for imaging supplies

# General Plastic Industrial Co., Ltd.

## 6128

Investor Conference  
Executive Vice President  
Steven Huang  
2021.11.29



**Together,  
We Are Stronger**

**KATUN GPI**



**KATUN** & **Cartridge Web™**  
*alternative solution for imaging supplies*



# Tourist Hotel Department - Taichung Harbor Hotel

- The first and only four-star★★★★ international tourist and business hotel at the central Taiwan coastline.
- Maximized housing services, stable high-margin business travelers and domestic individual tourists
- Significant growth in the occupancy rate and the average Room Rate have increased profitability
- Significant growth in 2020 sales revenues.



台中港酒店  
TAICHUNG HARBOR HOTEL

**Together,  
We Are Stronger**

**KATUN** **GPI**



**KATUN** & **Cartridge Web™**  
*alternative solution for imaging supplies*

# Imaging Consumables Department Main Product Lines



**KATUN®**

**Cartridge Web™**  
*alternative solution for imaging supplies*

**Together,  
We Are Stronger**

**KATUN** GPI



**KATUN** & **Cartridge Web**  
*alternative solution for imaging supplies*

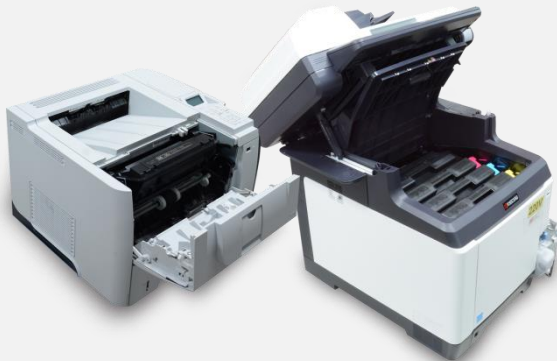

## Printer Toner Cartridge



## Copier Toner Cartridge



## Parts

# GPI

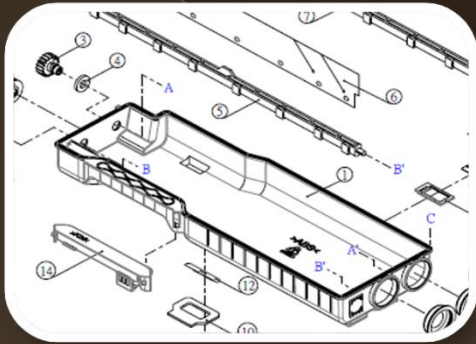

R&D



Assembly



Toner Filling



Packaging

100%  
NEW  
COMPATIBLE  
Toner Cartridge



**KATUN**<sup>®</sup>

**Cartridge Web**<sup>™</sup>  
alternative solution for imaging supplies



General Plastic Industrial Co., Ltd.



**KATUN**  
**ACCESS**

**Cartridge Web**<sup>TM</sup>  
*alternative solution for imaging supplies*

**KATUN**  
**BUSINESS COLOR**

**mediaSciences**<sup>®</sup>  
*Imaging the World in Color™*

**KATUN**  
*Select*<sup>TM</sup>

**KATUN**  
**BUSINESS INK**<sup>™</sup>

**Unmatched Global Footprints**



# Global Logistics of GPI & KATUN



Note : Katun has 3PL sites in North America and Brazil to leverage its efficiency



**Together,  
We Are Stronger**



**KATUN** & **Cartridge Web™**  
alternative solution for imaging supplies

# Gross Profit, Income & EPS

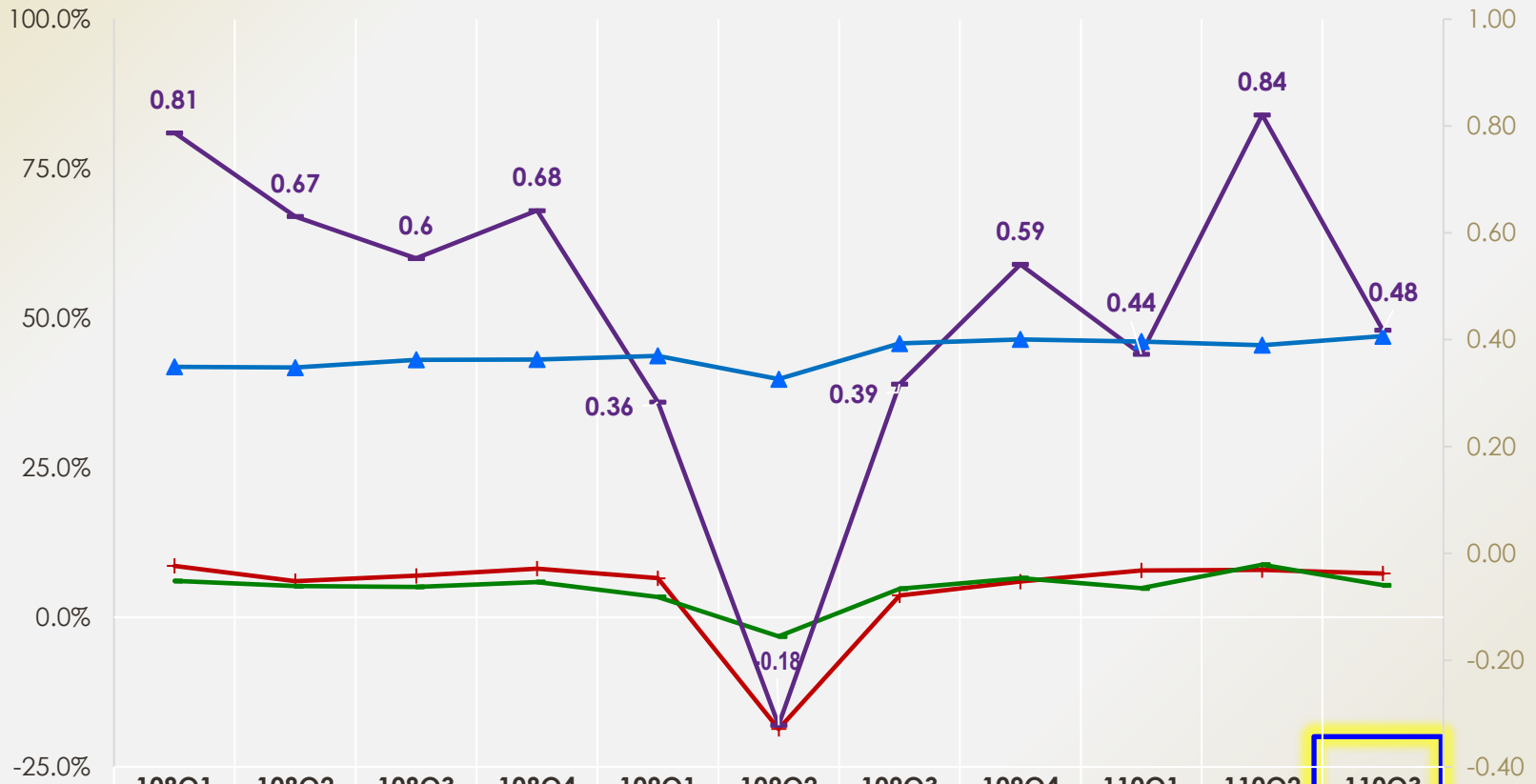

Operating Profit (%)	8.6%	6.1%	7.0%	8.2%	6.6%	-18.6%	3.7%	6.0%	7.8%	7.9%	7.3%
Net Profit (%)	6.1%	5.2%	5.1%	5.9%	3.4%	-3.2%	4.8%	6.6%	4.9%	8.8%	5.4%
EPS	0.81	0.67	0.6	0.68	0.36	-0.18	0.39	0.59	0.44	0.84	0.48
Gross Profit(%)	34.9%	34.8%	36.2%	36.3%	37.0%	32.6%	39.3%	40.1%	39.7%	39.0%	40.7%

## Proportion of Consolidated Sales

**2020**

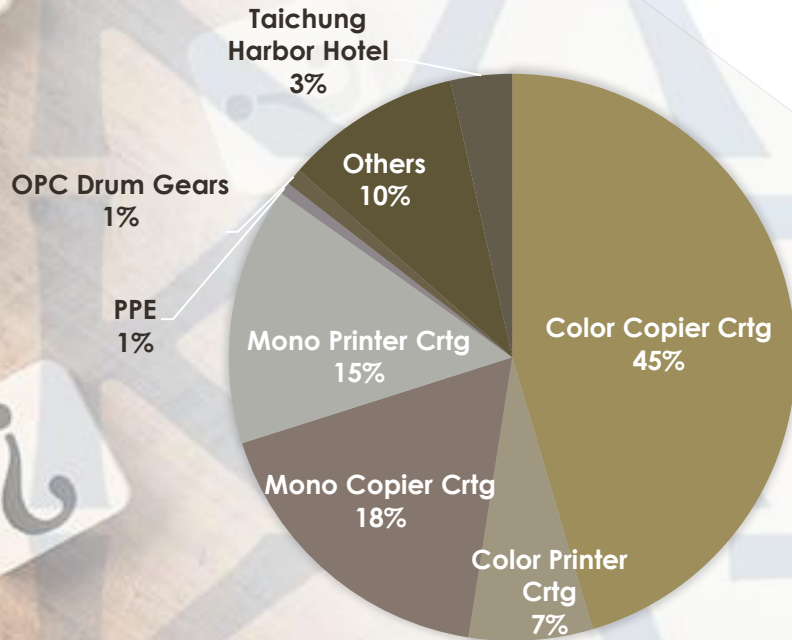

**2021 Q1-Q3**

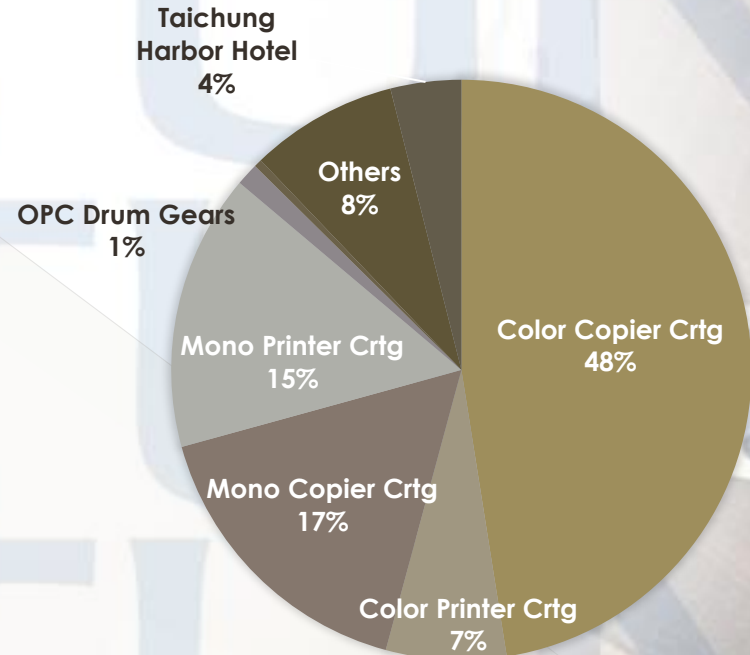



**KATUN**



## 2020 Area Proportion of Group Sales

Region	Country	% of Total Revenue
EAME	Netherlands	15.84%
EAME	Italy	11.11%
EAME	Germany	9.01%
EAME	France	8.87%
EAME	U.K. Ireland	8.57%
EAME	Spain	5.48%
<b>EAME Total</b>		<b>58.89%</b>

Region	Country	% of Total Revenue
NABU	USA	18.19%
LABU	MEXICO	6.67%
LABU	BRAZIL	4.50%
<b>America Total</b>		<b>29.35%</b>
ASIA	Taiwan	4.82%
ASIA	China	0.48%
ASIA	Japan	0.23%
ASIA	Other Countries	6.23%
<b>Asia Total</b>		<b>11.76%</b>

# GPI 2021 Retrospect

- ⦿ Soaring cost of raw material and freight rate impacted the gross and profit margin.
- ⦿ Controlling the cost and expense, maintaining the premium after-sales service
- ⦿ Q3 sales recovered to 80% of the pre-pandemic level. Q4 sales projection was to approach the pre-pandemic level more closely.
- ⦿ The synergy of procurement, logistics, and R&D. Vertical integration of Asian supply chain. Global brand marketing of Katun and the enhancement of its distribution channel control.
- ⦿ Flexible but reasonable pricing strategy to ensure a balanced competition among Katun and GPI's direct customers

**Together,  
We Are Stronger**

KATUN GPI



GPI CO., LTD.

KATUN  Gartridge Web™  
alternative solution for imaging supplies

# KATUN 2021 Retrospect

- ⦿ Steady profitability in post-pandemic & Well-controlled overheads
- ⦿ Operation resumed in global key markets. Print volume increased with the reopening of offices and schools.
- ⦿ Marketing enhancement in IP-valued countries. One-stop shop to satisfy customers' need
- ⦿ Deeper cultivation in emerging markets. Aggressive development in China and other Asian countries.
- ⦿ R&D center shifted to Taiwan HQ for synergy, acceleration of development, and timely schedule of new product launch.



GPI CO., LTD.

**KATUN®**

 **Gartridge Web™**  
alternative solution for imaging supplies

**Together,  
We Are Stronger**

KATUN GPI



KATUN  **Gartridge Web™**  
alternative solution for imaging supplies

# Taichung Harbor Hotel 2021 Retrospect

- ⦿ While others were heavily affected by the pandemic, Taichung Harbor Hotel was one of the few star-rated hotels that grew against the wind and made a profit.
- ⦿ The increasing occupancy rate, revenue, and profit
- ⦿ Steady customer source with the support of offshore wind power projects and outlet mall
- ⦿ The only star-rated and reputational hotel in the coastal area of middle Taiwan



**KATUN®**

 **Cartridge Web™**  
alternative solution for imaging supplies

**Together,  
We Are Stronger**

KATUN GPI



KATUN  Gartridge Web™  
alternative solution for imaging supplies

# 2022 Prospect

- To give close attention to the continued impact of Covid-19, especially to the potential influence of the 4th wave in Europe
- Cost and expense control and the recovering sales in regions will keep the momentum of Q4 towards 2022.
- To channel in eco-friendly or recycled material to seek for a further breakthrough towards EU green business opportunity
- To lead the synergy of R&D, procurement, logistics, and so on with the coming construction completion of the new operation center



**KATUN®**



**Together,  
We Are Stronger**

KATUN GPI



KATUN & Cartridge Web™  
alternative solution for imaging supplies

# 2022 Prospect

- To show the aftermarket the strength of the unification between GPI and Katun; to seek more opportunities to collaborate with OEM
- To adjust product portfolio to cope with the market changes that hybrid working mode is the new normal
- To outsource logistics to adjust loading capacity of containers and to cope with the soaring freight rate



**KATUN®**





**Together,  
We Are Stronger**

**KATUN GPI**



**KATUN** & **Cartridge Web™**  
*alternative solution for imaging supplies*

# Q & A



**KATUN®**

**Cartridge Web™**  
*alternative solution for imaging supplies*

**Together,  
We Are Stronger**



GPI CO., LTD.

**KATUN**

**Cartridge Web™**  
*alternative solution for imaging supplies*

# THANK YOU



**KATUN®**

**Cartridge Web™**  
*alternative solution for imaging supplies*