

上福全球科技(股)公司 6128

General Plastic Industrial Co., Ltd.

業績發表會

主講人

執行副總 黃懷德



2016.04.12



公司介紹沿革及里程碑



1978



- 上福全球科技公司成立

1997

- ISO 9001 認證



2003

- 上福全球股票正式掛牌上市 · 股票代號6128

2008

- 成立自有品牌Cartridge Web 行銷全球碳粉匣市場



2012

- ISO 14001 認證



2013

- 3月台中港酒店正式開幕



Cartridge Web™
alternative solution for imaging supplies

GPI 主要產品介紹

Main Product Lines



GPI Products Quality/Service/Value

The Cartridge Pros!

影印機 Copier

印表機 Printer



Waste
Toner Container

Copier / Printer
Toner Cartridge

廢粉回收槽



Organic Photo
Conductor Drum Gear

影印機碳粉匣
印表機碳粉匣

感光滾筒齒輪



Cartridge Web™
alternative solution for imaging supplies

COPIER
TONER
CARTRIDGE

影印機碳粉匣



PRINTER
TONER
CARTRIDGE

印表機碳粉匣



Cartridge Web™
alternative solution for imaging supplies

OPC
DRUM
GEAR

感光滾筒齒輪



GPI在做什麼？

GPI在做什麼？

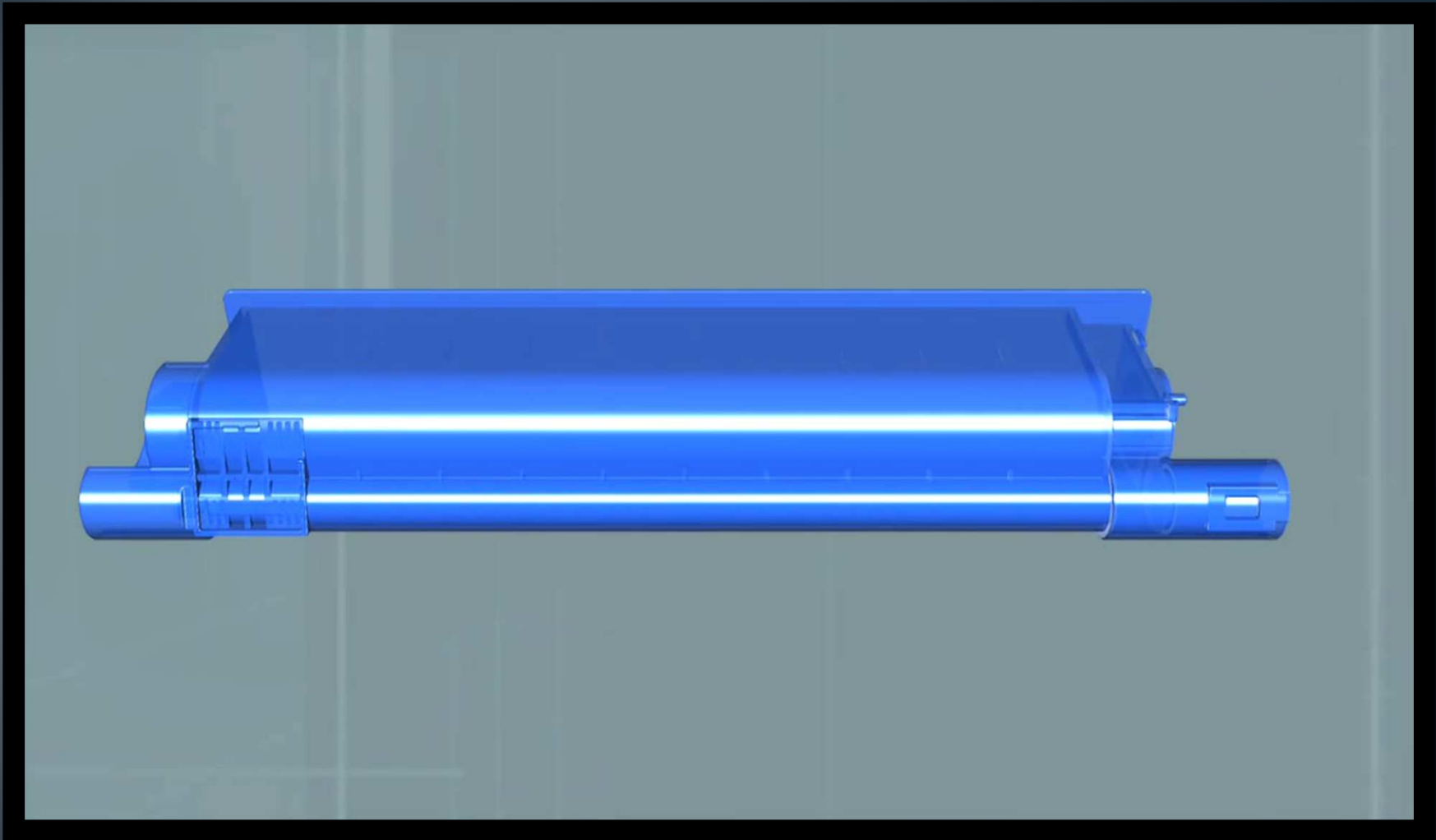

Cartridge Web™
alternative solution for imaging supplies

GPI 生產作業流程

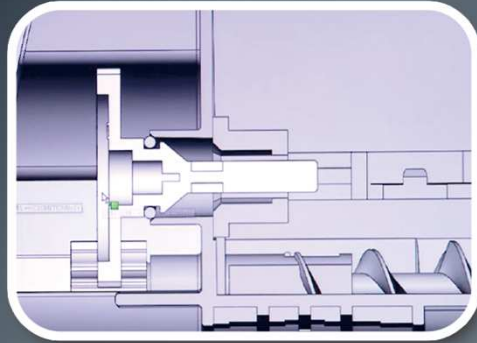

研發



組裝



充填



包裝



100%
NEW
COMPATIBLE
Toner Cartridge



Cartridge Web™
alternative solution for imaging supplies

QUALITY / SERVICE / VALUE

GPI優勢分析



Cartridge Web™
alternative solution for imaging supplies

GPI優勢分析



Cartridge Web™
alternative solution for imaging supplies

- 規模經濟生產
- 尊重智產權
- ISO認證
- ECO-Friendly (ROHS/REACH)





- 列印表現媲美原廠
- R&D設計團隊
- 自行開發模具能力
- 精準成本控制

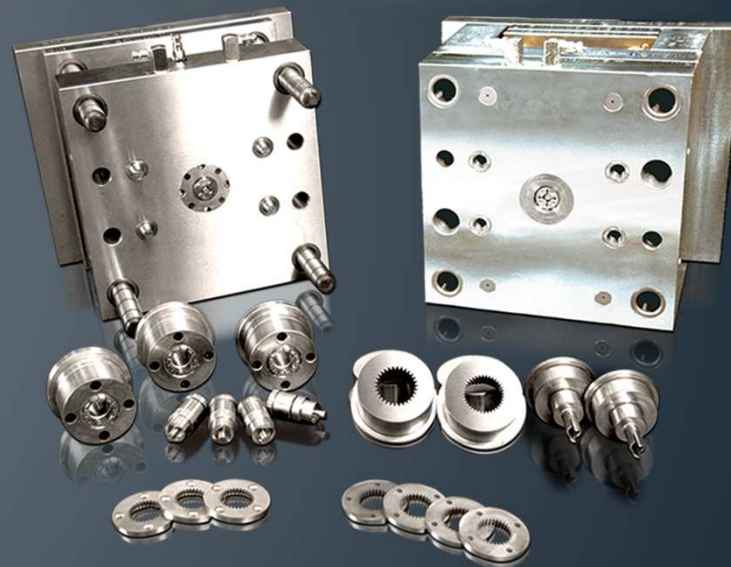

GPI優勢分析

Made in Taiwan 為品質最佳保證

- 品質
- 服務
- 差異性



Cartridge Web™
alternative solution for imaging supplies

The Cartridge Pro!



塑膠射出成型達人



Cartridge Web™
alternative solution for imaging supplies



自有品牌成功行銷歷程



Cartridge Web™
alternative solution for imaging supplies

www.cartridgeweb.com

CW主要產品介紹

- 主流品牌之再生卡匣
 - HP
 - Samsung
- 利基產品之全新相容卡匣
 - Xerox
 - Dell
 - Oki Data
 - Kyocera



Cartridge Web™
alternative solution for imaging supplies

CW 104年銷售區域佔比及 歐洲代理商一覽表

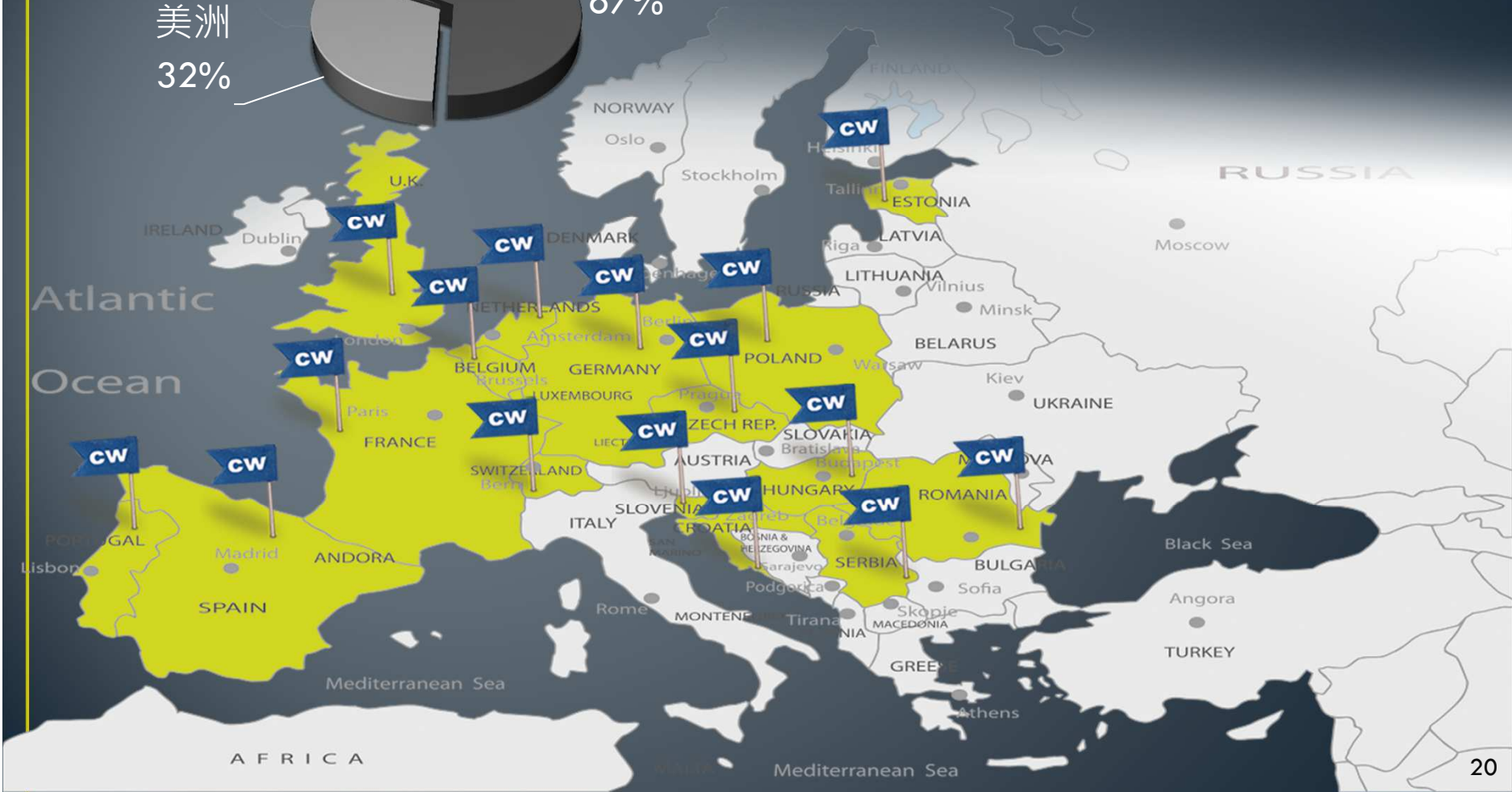
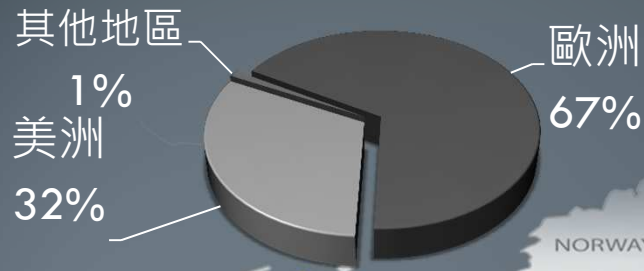



CW優勢分析

CW優勢分析



- 與大陸價格紅海做出品牌差異化
- 完善的售後服務(含客訴處理)
- 尊重原廠專利智慧財產權
- One Stop Shop (一次購足)
- 穩定可信賴的品質水準
- 業界最高產品良率
- 代理銷售網路綿密
- 後勤倉儲系統完善



CW品牌行銷成功故事

國際耗材展



CW品牌行銷成功故事

Cartridge Web
alternative solution for imaging supplies

← Problem
Solution →

SUCCESS IS SIMPLE.
Do what's right, the right way,
at the right time.

NOW, it's the right time to choose Cartridge Web™ as your toner cartridge partner and head down the path to success together.

iLEX 2015
Bismarck County Convention Center
Irish, September 25-26
March 19-22, 2015
Booth No. 1019

Now you can expect more.

Our market is saturated with low quality, OEM patent knockoffs. Make your business unique by carrying Cartridge Web™ products that are cleared from patent infringement, best quality to differentiate yourself from the rest of market. Your customers will love you for the decision you made today!

Cartridge Web
alternative solution for imaging supplies

Takes you further!

Switch & Match

Switch to Cartridge Web products as your ultimate alternative to OEM supplies. Our products performance meets OEM's quality standards, along with better service and awesome prices.

Time To Make A change

Why Not Cartridge Web?

Our market is saturated with low quality, OEM patent knockoffs. Make your business unique by carrying Cartridge Web™ products that are cleared from patent infringement, best quality to differentiate yourself from the rest of market. Your customers will love you for the decision you made today!

paperworld **Always different**

31.1 - 3.2.2015, Frankfurt am Main
stand No. 60 B57

業界雜誌



Cartridge Web™
alternative solution for imaging supplies

CW品牌行銷成功故事

• B2B網站

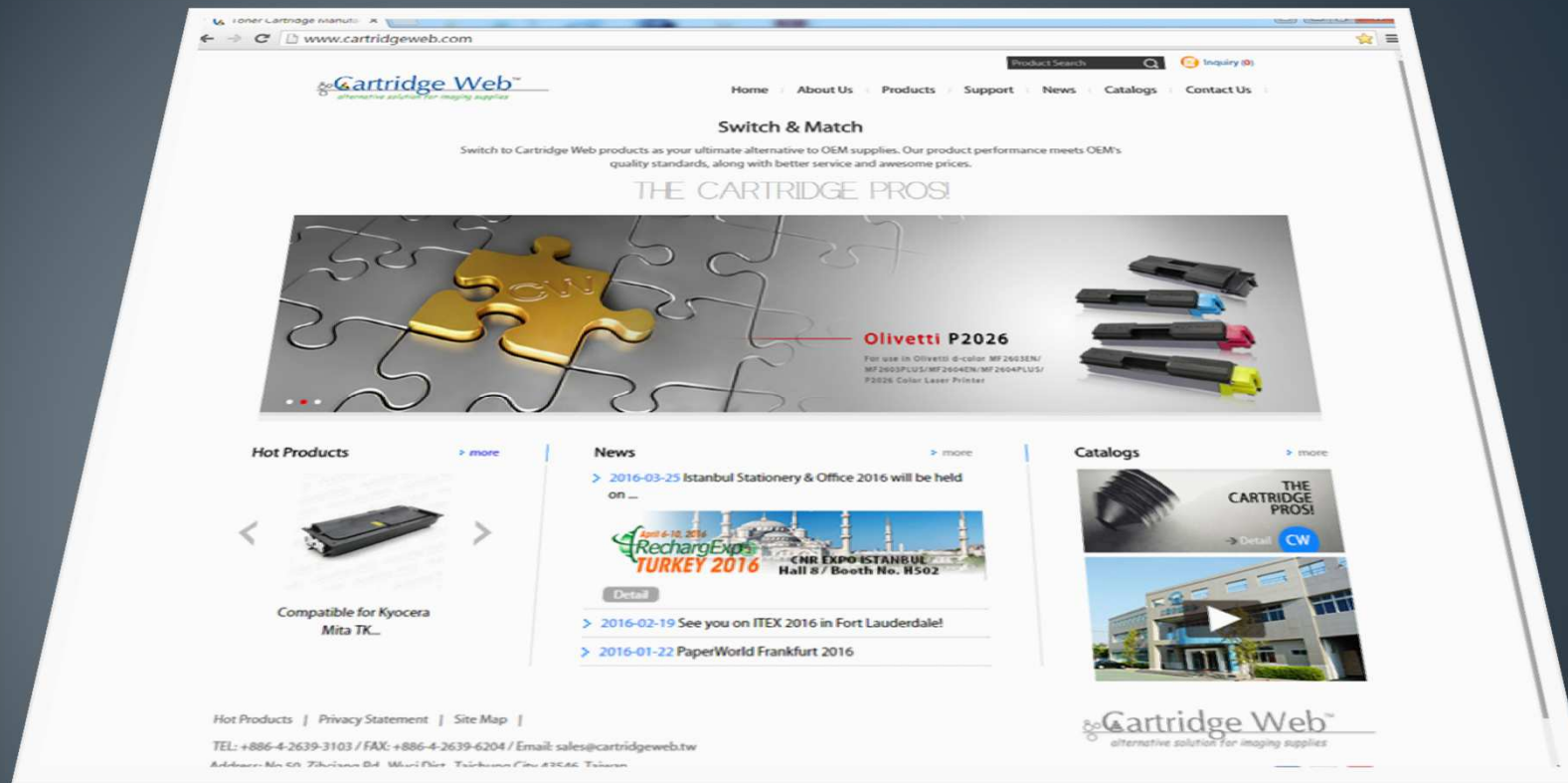

• 網路平台

- Amazon
- e-Bay
- New Egg



Cartridge Web™
alternative solution for imaging supplies

www.cartridgeweb.com

Marketing Support 提升品牌曝光率



海外倉儲物流系統



USA



Netherlands



Taiwan



最即時性的配送服務

M A R K E T I N G

自有品牌年營收

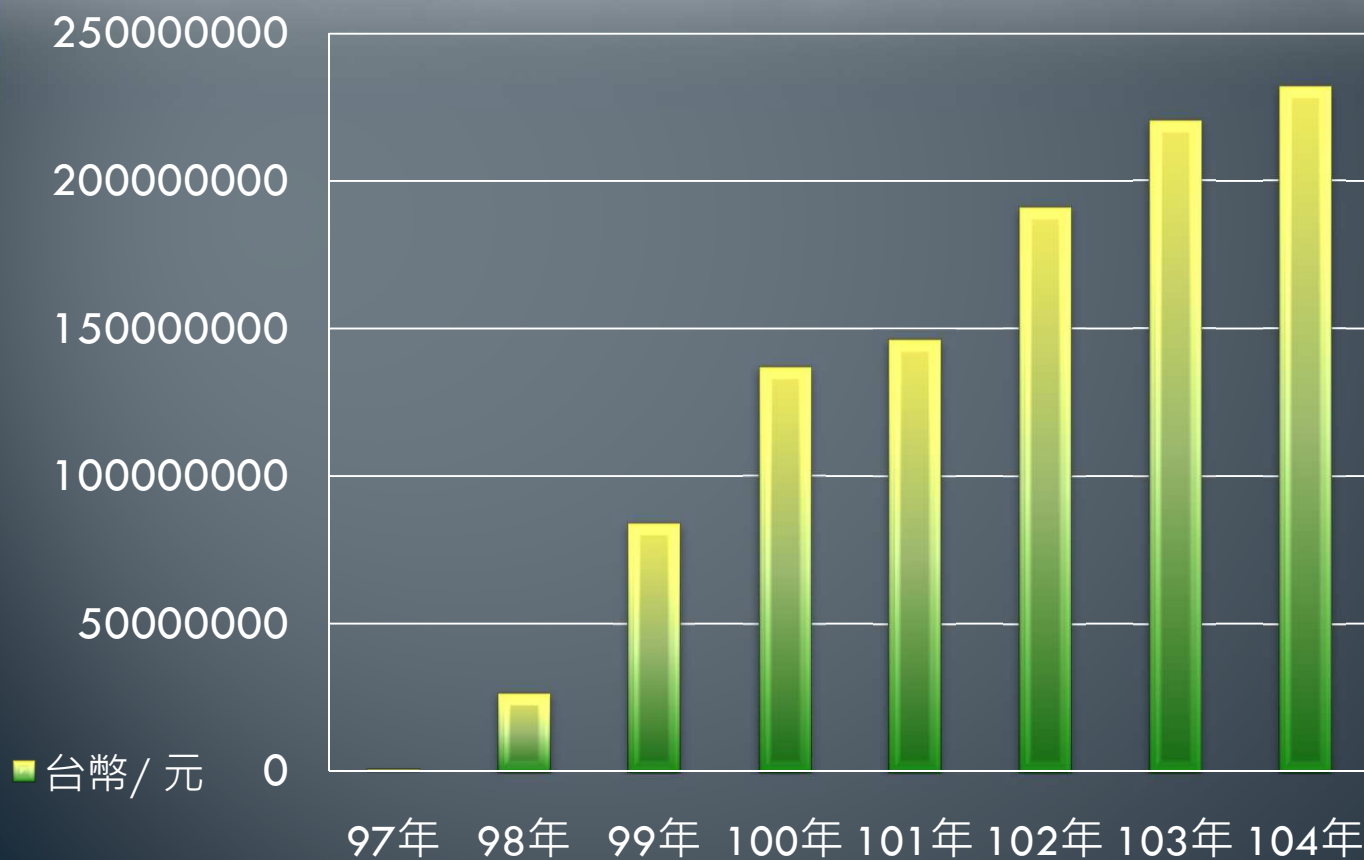

Cartridge Web™
alternative solution for imaging supplies

GPI各地區別營收比重表

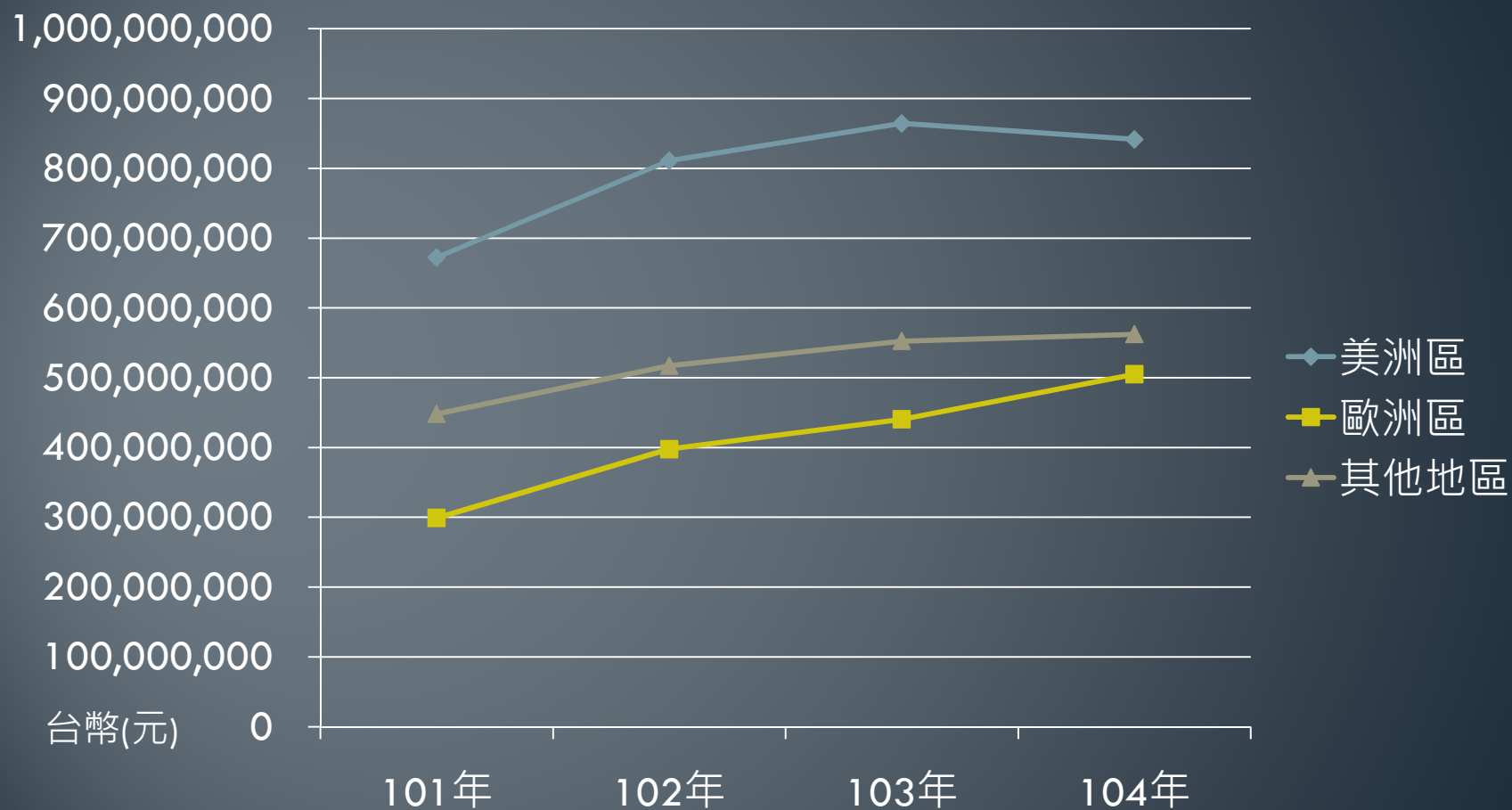

GPI各地區別營收比重表

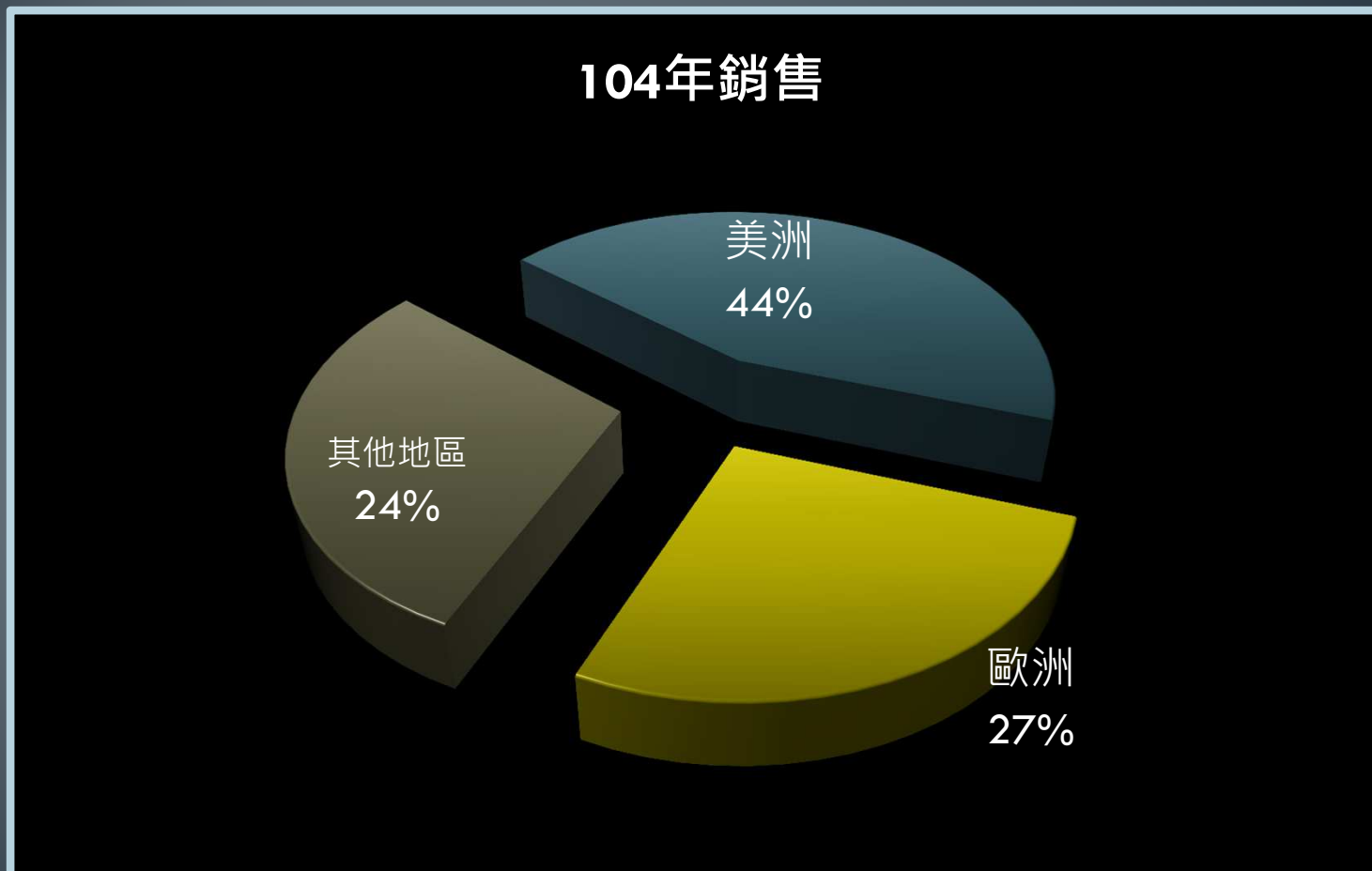

GPI三高列表 (毛利率、淨利率、現金殖利率)

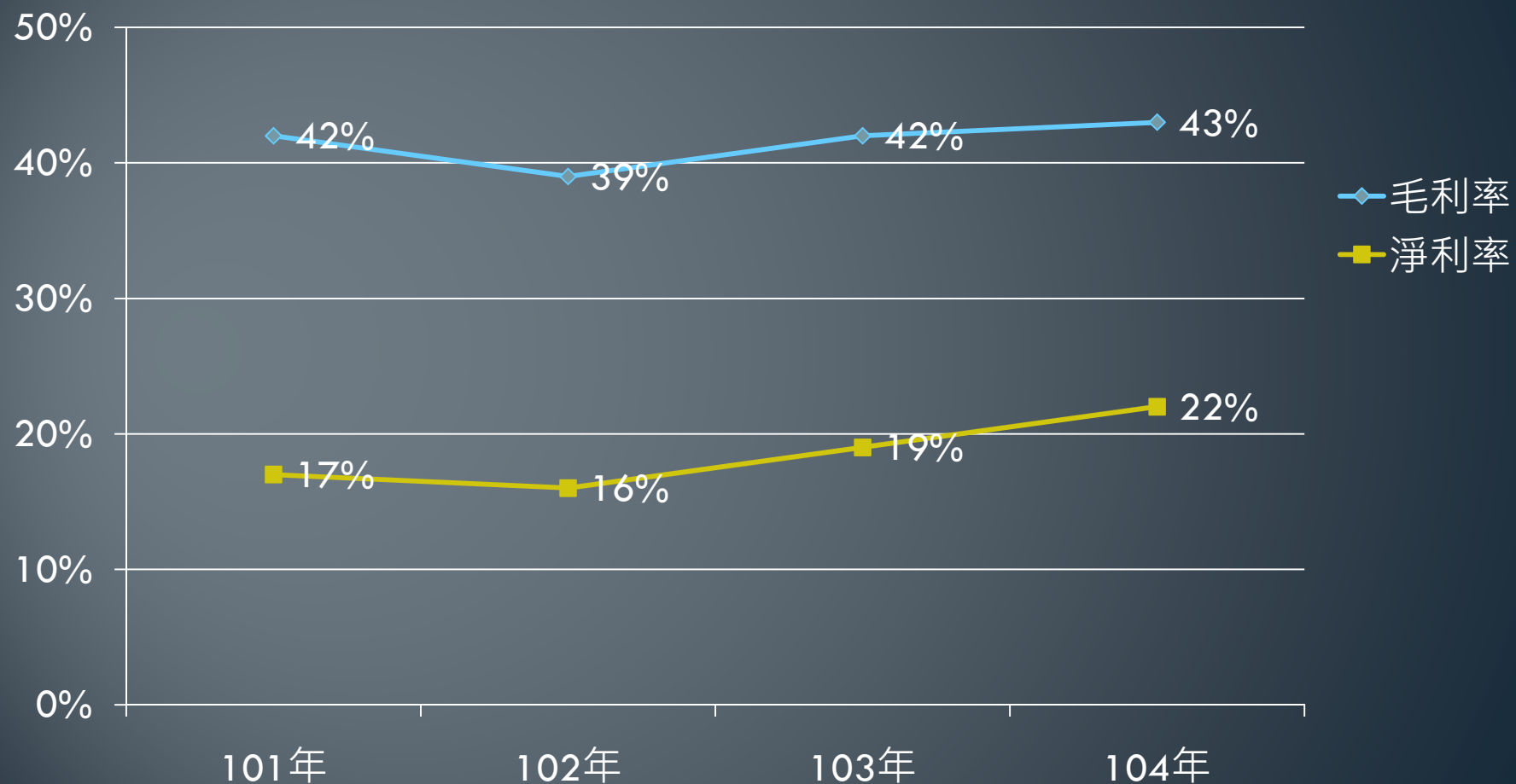

GPI三高列表 (毛利率、淨利率、現金殖利率)

現金殖利率

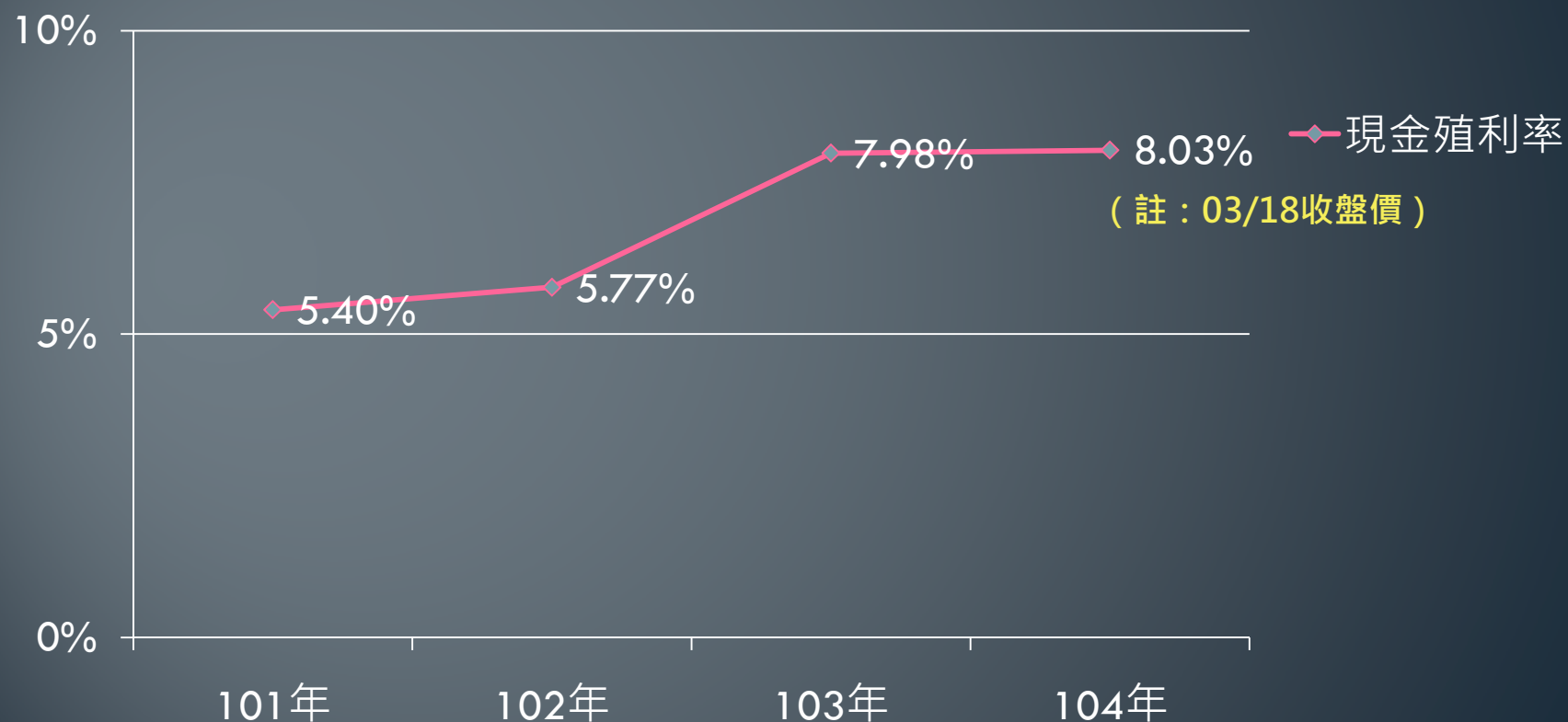



投資焦點

選股眉角》看現金殖利率，免受外資擺布 跟著年報搶先挑 14檔高息股出列

文藝艷畫

負利率、低利率環境中，高息股投資報酬率遠勝定存，挑選獲利持續成長個股，穩定領股息的同时，股價也獲支撐。

每年三月底，是上市櫃公司公布年度財報的截止日期，也是股東用放大鏡仔細瞧公司體質的時刻。目前台灣一千六百多家上市櫃公司，已有逾兩成公司公布年報。

其實，會提前公布年報的，大多是業績特別出色，或是營運很有規模的大公司。一、台股新投顧協理黃文清觀察，春江水暖，這些急性子公司，最能提前為投資人帶來喜氣騰騰。比起第一季至第三季報，在季底結算之後三個月後才公告周知，每年二月、三月上旬，都是財務數字空窗期，消息滿天飛，讓中小型股活動亂跳。隨著時序越接近三月底，年報數據陸續揭露，這些亂象

也會一回歸理性，讓數字說話，價值型投資人這時則從數字中飛梳低估值的好股。外資買超，拱高台股股價。然而，本年度年報旺季卻出現跟往年很不同的現象：外資大手筆一攔胡來，「只要年報一出來，股價馬上反應。」元富投顧總經理劉坤錫觀察，甚至早在年報出爐前，外資就憑著龐大研究資源，提前盤算。事實上，由於各國央行陸續實施低利率，負利率，讓台股平均約三、五%的高殖利率格外誘人，吸引外資在今年一月底開始買超台股，如今案

計對標，市價股票約兩億元，高居新興亞股之冠，遠比買超第一名的韓國高出數倍。這種豪氣買法把台股價位節節拱高，大盤指數如今來到九千點上下，基本面卻未出現明顯回溫，上檔空間有限，下檔風險不小。看得本土操盤人大嘆：「太野了，買者皆不手！」

「這時，高現金殖利率股進可攻退可守，是散戶從年報選股的最佳策略。」日盛投顧資深協理鍾國忠分析，預期未來很長一段時間內，高息股投資報酬率遠勝定存，仍將穩居盤面主流，只要挑選獲利持續成長個股就能在領股息同時，股價也獲支撐。

同時年報一起公布的，還有各公司的股利政策，現金股利當道更助長了高息股投資風潮。鍾國忠觀察，由於公司帳上現金在低利率環境中不容易找到投資標的，加上不景氣無擴廠需求，竟有不少公司出現

「賺五毛配一元」的慷慨舉動，包括奇摩、台南企業等公司的現金股息都是每股稅後盈餘（EPS）的兩倍以上。

景氣仍差，出手留意五地雷

然而，在股價大多已反映年報獲利的情況下，要避免費到太貴的高息股，或想在之後陸續公布的年報中搶到便宜好貨，要仔細檢視報章中細節，股市專家建議今年要留意五大重點。

第一，老大、老二好，不見得老三表現就好。黃文清指出，整體大環境不佳，很難出現整個產業都齊聲歡騰的盛況，這時看到財報提前公布的一線公司表現佳，別貿然提前布局二、三線公司。實際上很可能只有老大、老二吃牛肉，排名後面的連牛肉湯都沒得喝。

第二，對營收增加、獲利卻下滑的公司保持距離。鍾國忠分析，從目前公布的年報數字觀察，這類公司數量明顯增加，而這代表公司很可能藉由削價競爭對抗不景氣，對未來

營運展望並不是件好事。第三，留意匯價影響。人民幣大幅貶值，國際貨幣波動劇烈，上市櫃公司在中國投資的匯兌損失較往年嚴重。例如高成長股的和碩，匯損侵蝕EPS達一、三、五元，但不妨礙以全年九、二、三元的EPS續創歷史新高。但驚穩健股而非高成長股的聯強，因提列中國事業體美元借款匯損，讓去年盈餘大幅縮水，較前年衰退二十七%。

第四，留意中國業務的應收帳



這14檔耐震股，逾半數是電子業

篩選條件：
1. 依現金殖利率大於4%
2. 每股稅後盈餘連續3年正成長
3. 連續3年穩定配發現金股息
4. 股東權益報酬率連續3年逾10%

股票 (代號)	產業別	03/18 收盤價	2013年 每股股利 (元)	現金殖利率 (%)
上緯 (6128)	電子	37.35	3	8.03
南漢 (3299)	電子	62.70	5	7.97
旺詮 (2437)	電子	52.80	4	7.58
基寶 (4527)	電腦機械	25.95	1.8	6.94
盛群 (6202)	電子	53.30	3.57	6.70
博太 (8109)	電子	72.40	4.5	6.22
艾訊 (3088)	電子	76.50	4.3	5.62
F-中租 (5871)	其他	56.10	3.1	5.53
實業 (8416)	電子	110.00	6	5.45
揚華電 (8142)	電子	164.00	7.75	4.73
瓦城 (2729)	觀光事業	234.00	10.6	4.53
數字 (5287)	電子	271.00	12	4.43
中復 (8917)	其他	93.00	4	4.30
聯鈞 (3450)	電子	153.50	6.5	4.23

整理：蘇麗姿



台股殖利率高，吸引國際熱錢湧入，正逢年報旺季，外資搶著對股價低估股出手。短期仍須留意是否有獲利了結賣壓。

商周報導 耐震電子股第一名！



這14檔耐震股，
逾半數是電子業

篩選條件：

1. 依現金股利殖利率大於4%
2. 每股稅後盈餘連3年正成長
3. 連3年穩定配發現金股息
4. 股東權益報酬率連3年逾10%

台股 (代號)	產業別	03/18 收盤價	2015年 現金股利 (元)	現金殖利率 (%)
上福 (6128)		37.35	3	8.03
昂漢 (3299)	電子	62.70	5	7.97
旺詮 (2437)		52.80	4	7.58
堃霖 (4527)	電機機械	25.95	1.8	6.94
盛群 (6202)		53.30	3.57	6.70
博大 (8109)	電子	72.40	4.5	6.22
艾訊 (3088)		76.50	4.3	5.62
F-中租 (5871)	其他	56.10	3.1	5.53
實威 (8416)	電子	110.00	6	5.45
振樺電 (8114)		164.00	7.75	4.73
瓦城 (2729)	觀光事業	234.00	10.6	4.53
數字 (5287)	電子	271.00	12	4.43
中保 (9917)	其他	93.00	4	4.30
聯鈞 (3450)	電子	153.50	6.5	4.23

整理：蔡靚萱



Cartridge Web™
alternative solution for imaging supplies

GPI毛利為何高之原因探討?



GPI毛利為何高之原因探討

- 彩色產品佔比逐年增加
- 原物料成本管控得宜
- 靈活之定價策略
- 專利的門檻



GPI如何做出差異性?

HOW DOES GPI STAND OUT!?



Cartridge Web™
alternative solution for imaging supplies

GPI如何做出差異性?



- 發展自有品牌 **CartridgeWeb**，行銷全球
- 與優質客戶結盟成第三勢力，爭奪原廠市佔率 (Market Share)
- **TOTAL SOLUTION** (品質，服務，智慧財產權)

合併資產負債表

								單位：新台幣仟元	
年度	101年		102年		103年		104年		
項目	金額	%	金額	%	金額	%	金額	%	
流動資產	700,144	30%	844,458	32%	984,670	27%	1,238,124	34%	
資產總額	2,317,616	100%	2,662,066	100%	3,682,978	100%	3,643,677	100%	
流動負債	586,886	25%	585,303	22%	1,494,692	41%	1,337,189	37%	
負債總額	741,411	32%	1,008,106	38%	1,917,433	52%	1,784,189	49%	
股本	910,887	39%	910,887	34%	910,887	25%	910,887	25%	
資本公積	239,940	10%	240,357	9%	240,357	7%	239,237	7%	
保留盈餘	435,556	19%	505,217	19%	584,125	16%	657,002	18%	
股東權益總額	1,576,205	68%	1,653,960	62%	1,765,545	48%	1,859,488	51%	



合併綜合損益表

								單位：新台幣仟元	
年度	101年		102年		103年		104年		
項目	金額	%	金額	%	金額	%	金額	%	
營業收入	1,419,529	100%	1,725,652	100%	1,857,185	100%	1,908,821	100%	
營業毛利	590,091	41.2%	677,947	39.3%	782,467	42.1%	829,226	43.4%	
營業利益	255,148	17.9%	271,019	15.7%	338,246	18.2%	351,494	18.4%	
營業外收入及支出	(7,286)	-0.5%	9,945	0.58%	11,121	0.6%	62,253	3.3%	
稅前淨利	247,862	17.5%	280,964	16.3%	349,367	18.8%	413,747	21.7%	
本期淨利	196,092	13.8%	219,734	12.7%	280,284	15.1%	336,925	17.7%	
每股盈餘	2.15		2.41		3.08		3.70		



GPI競爭策略及產業核心價值

- 高差異產品發展
- 高品質品牌經營
- 高獲利市場經營
- 高成長市場行銷
- 高強度專利構築



調查指出 碳粉卡匣全球市場比重

全球碳粉卡匣出貨量

2015年GPI碳粉匣出貨量約1,000萬支

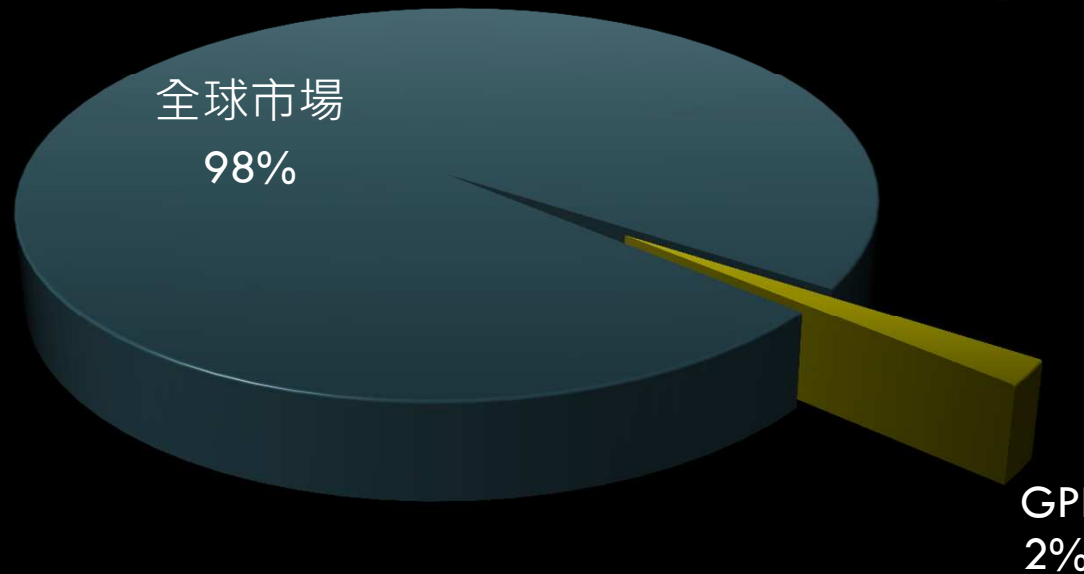

2015全球碳粉卡匣出貨量約5億支



GPI未來發展重點



GPI未來發展重點



- 持續開發新市場
- 持續強化自有品牌 Cartridge Web全球行銷
- 自有專利
- 同業結盟
- 擴大產品線
- 成像機構組
- 擴大彩色產品成果



Cartridge Web™
alternative solution for imaging supplies



Q & A



Thank You for Your Attention.



www.facebook.com/cartridgewebTW



www.youtube.com/watch?v=lyQ8hshpndI